

Mathematical Modeling of Chemical Processes

Part II

Continuous Stirred-Tank Reactor (CSTR)

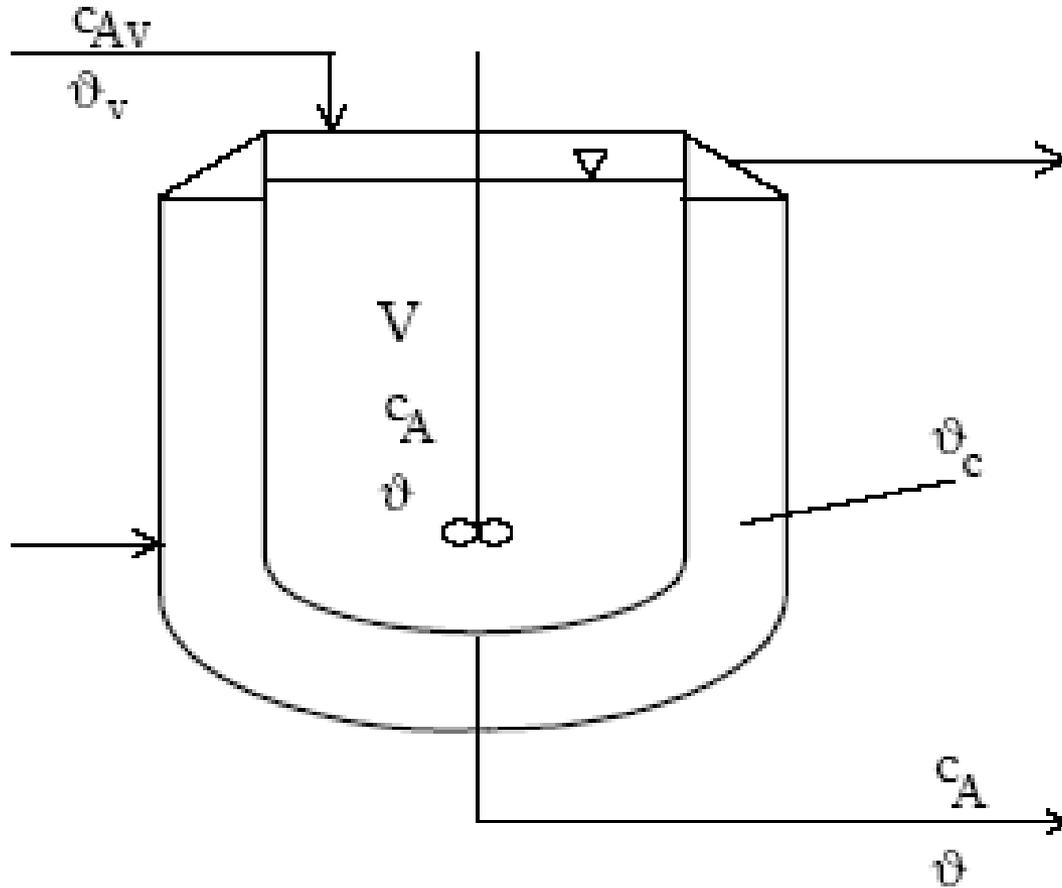

Continuous Stirred-Tank Reactor (CSTR)

Assumptions

- neglected heat capacity of inner walls of the reactor, constant density and specific heat capacity of liquid,**
- constant reactor volume, constant overall heat transfer coefficient, and**
- constant and equal input and output volumetric flow rates.**
- the reactor is well-mixed.**

Control loop for the Stirred Heating Tank

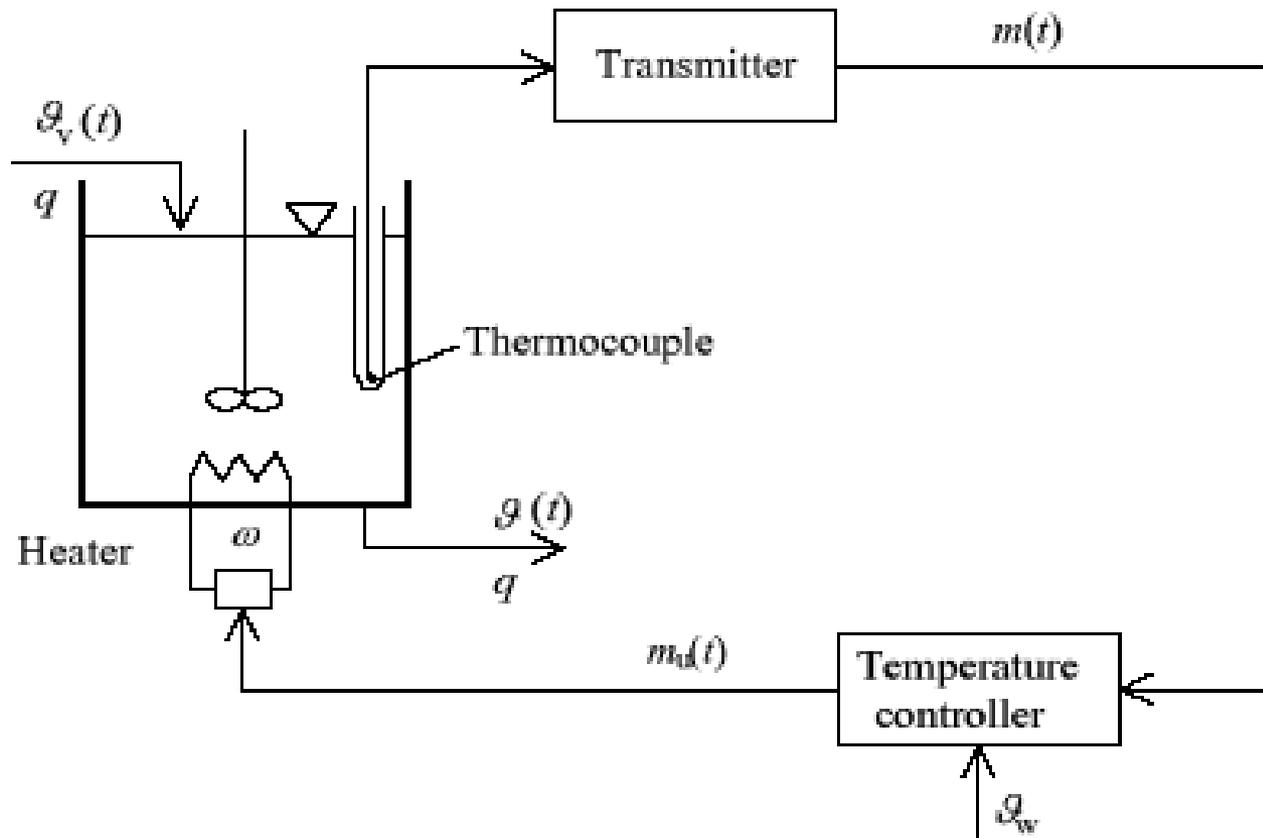

Mathematical model of a thermocouple

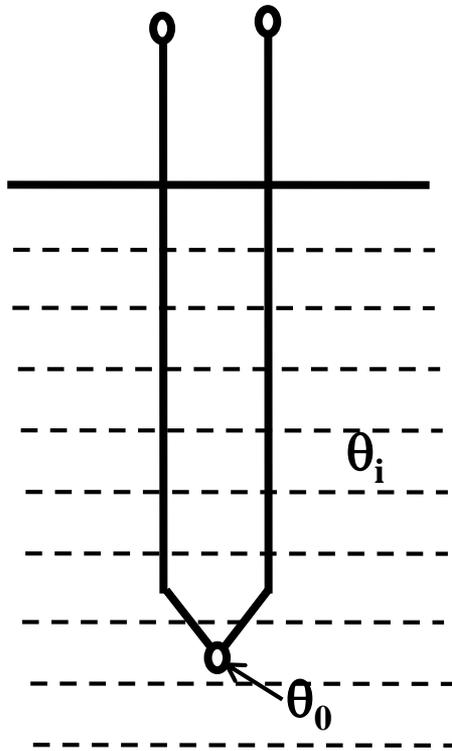

a) bare thermocouple

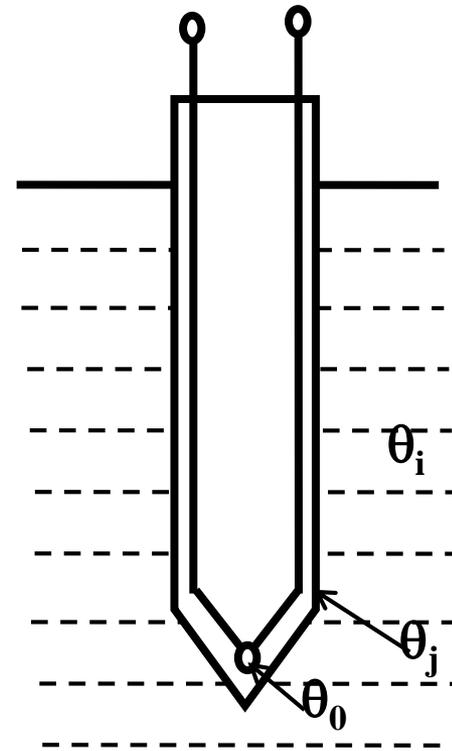

b) thermocouple with protect jacket

Blending system Control Method

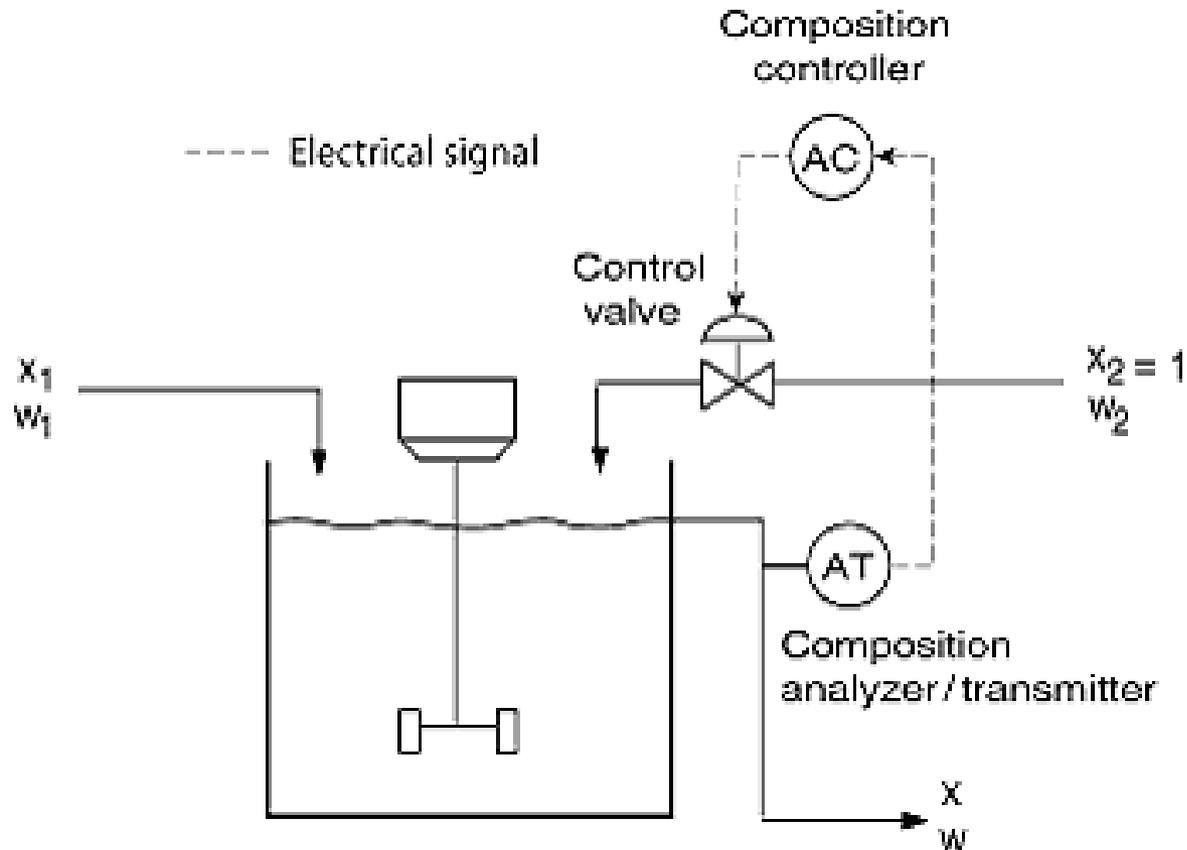

Modeling the pneumatic control valve

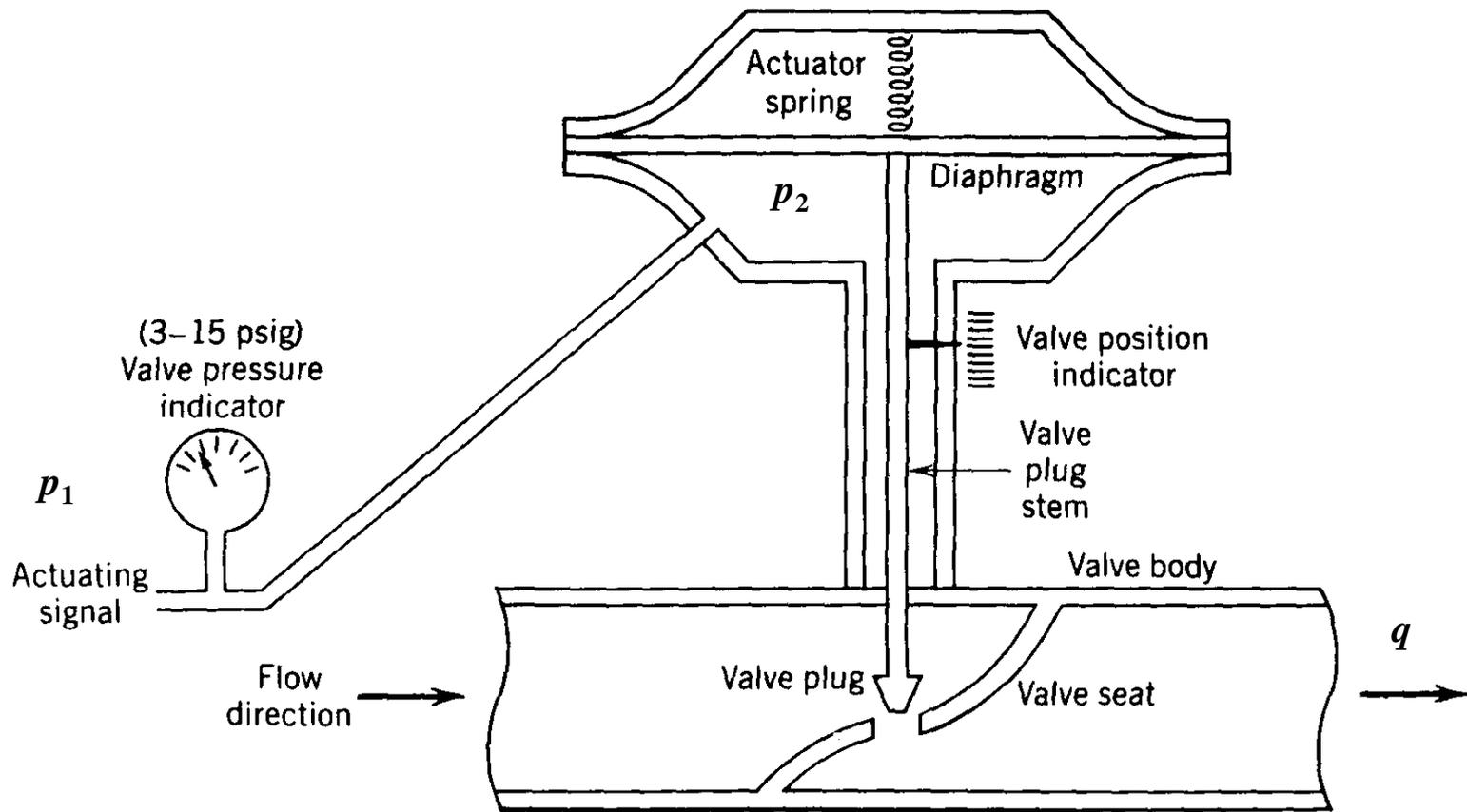

Element Time Responses

- **first order element**

$$\tau \frac{dy(t)}{dt} + y(t) = Kx(t)$$

- **Transfer function**

$$G(s) = \frac{Y(s)}{X(s)} = \frac{K}{\tau s + 1}$$

Element Time Responses

- **Step input $x(t) = MU(t)$**

$$Y(s) = G(s)X(s) = \frac{K}{\tau s + 1} \cdot \frac{M}{s}$$

$$y(t) = \mathcal{L}^{-1} \left[\frac{K}{\tau s + 1} \cdot \frac{M}{s} \right] = KM \left(1 - e^{-\frac{t}{\tau}} \right)$$

- **When $M=1$ (unit step input),**

$$y(t) = K \left(1 - e^{-\frac{t}{\tau}} \right)_{t=\tau} = 0.632$$

Element Time Responses

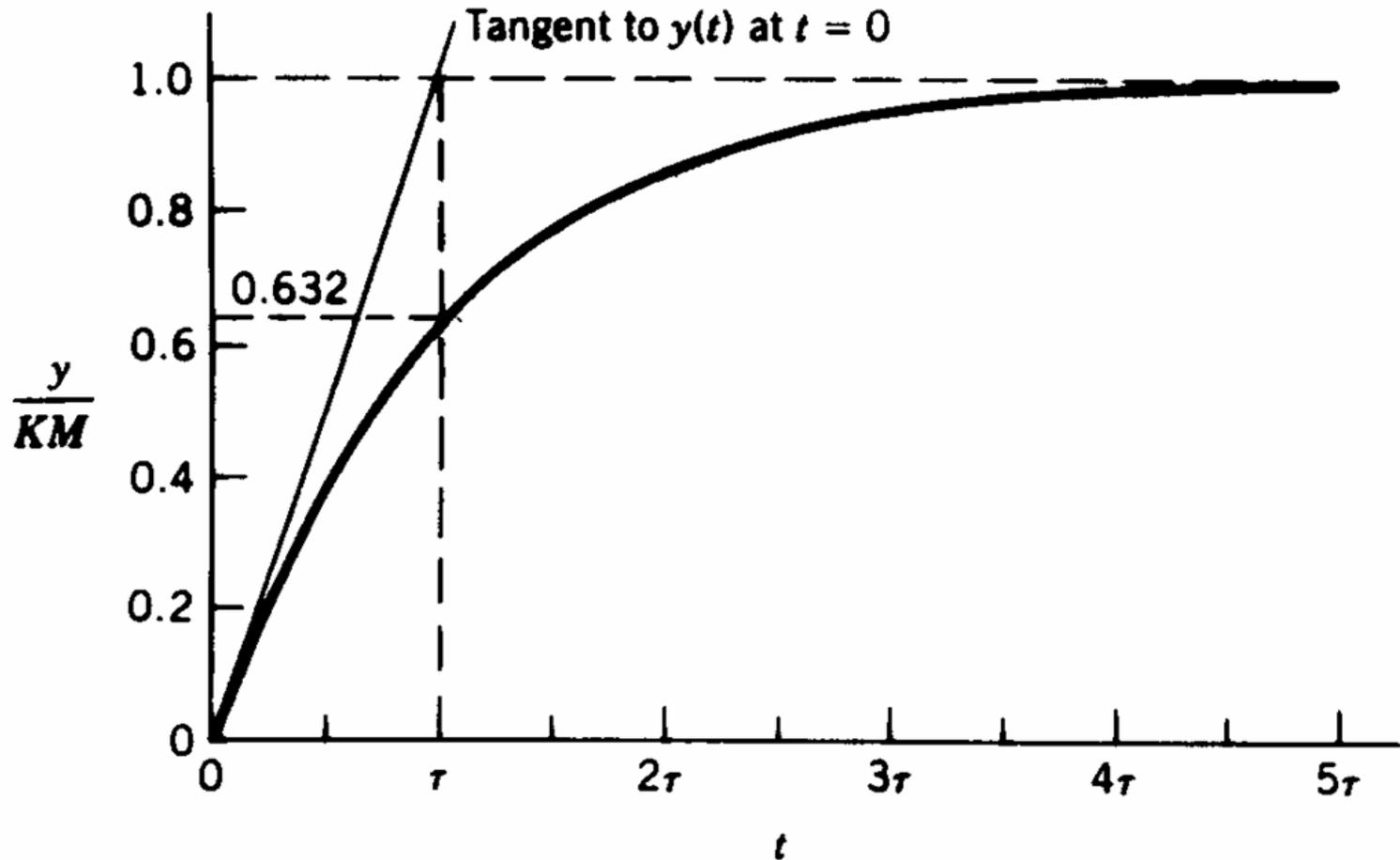

Element Time Responses

- **Second order element**

$$\tau_m^2 \frac{d^2 y(t)}{dt^2} + 2\zeta\tau_m \frac{dy(t)}{dt} + y(t) = x(t)$$

$$G(s) = \frac{Y(s)}{X(s)} = \frac{1}{\tau_m^2 s^2 + 2\zeta\tau_m s + 1}$$

$$= \frac{\omega_0^2}{s^2 + 2\zeta\omega_0 s + \omega_0^2}$$

Second order element

- Given a step input $x(t) = MU(t)$,

$$Y(s) = G(s)X(s) = \frac{\omega_0^2}{s^2 + 2\zeta\omega_0s + \omega_0^2} \cdot \frac{M}{s}$$

- Use notations in Chapter 4, and let $M=1$ (unit step)

$$C(s) = \frac{\omega_n^2}{s(s^2 + 2\zeta\omega_n s + \omega_n^2)}$$

Second order element

- **Factoring the denominator**

$$C(s) = \frac{\omega_n^2}{s(s + \zeta\omega_n - \omega_n\sqrt{\zeta^2 - 1})(s + \zeta\omega_n + \omega_n\sqrt{\zeta^2 - 1})}$$

- **Case A damping ratio equals unity $\zeta = 1$**

$$C(s) = \frac{\omega_n^2}{s(s + \omega_n)^2}$$

Second order element

- **Partial fraction expansion**

$$\begin{aligned} C(s) &= \frac{K_1}{s} + \frac{K_2}{(s + \omega_n)^2} + \frac{K_3}{(s + \omega_n)} \\ &= \frac{1}{s} + \frac{-\omega_n}{(s + \omega_n)^2} + \frac{-1}{(s + \omega_n)} \end{aligned}$$

- **The time domain responses of output**

$$c(t) = 1 - \omega_n t e^{-\omega_n t} - e^{-\omega_n t}$$

Second order element

- **Case B damping ratio greater than unity $\zeta > 1$**

$$C(s) = \frac{K_1}{s} + \frac{K_2}{\left(s + \zeta\omega_n - \omega_n\sqrt{\zeta^2 - 1}\right)} + \frac{K_3}{\left(s + \zeta\omega_n + \omega_n\sqrt{\zeta^2 - 1}\right)}$$

$$C(s) = \frac{1}{s} + \frac{\left[2\left(\zeta^2 - \zeta\sqrt{\zeta^2 - 1} - 1\right)\right]^{-1}}{\left(s + \zeta\omega_n - \omega_n\sqrt{\zeta^2 - 1}\right)} + \frac{\left[2\left(\zeta^2 + \zeta\sqrt{\zeta^2 - 1} - 1\right)\right]^{-1}}{\left(s + \zeta\omega_n + \omega_n\sqrt{\zeta^2 - 1}\right)}$$

Second order element

- The time domain responses of output

$$c(t) = 1 + \left[2\left(\zeta^2 - \zeta\sqrt{\zeta^2 - 1} - 1\right) \right]^{-1} e^{-\left(\zeta - \sqrt{\zeta^2 - 1}\right)\omega_n t} \\ + \left[2\left(\zeta^2 + \zeta\sqrt{\zeta^2 - 1} - 1\right) \right]^{-1} e^{-\left(\zeta + \sqrt{\zeta^2 - 1}\right)\omega_n t}$$

- **Case C damping ratio less than unity $\zeta < 1$**

Let $\zeta = \cos \alpha$, and therefore $\sqrt{1 - \zeta^2} = \sin \alpha$

Second order element

- **Partial fraction expansion**

$$C(s) = \frac{1}{s} + \frac{e^{-j\alpha}}{2j \sin \alpha} \left(s + \zeta \omega_n - j \omega_n \sqrt{1 - \zeta^2} \right)^{-1} - \frac{e^{-j\alpha}}{2j \sin \alpha} \left(s + \zeta \omega_n + j \omega_n \sqrt{1 - \zeta^2} \right)^{-1}$$

- **The time domain responses of output**

$$c(t) = 1 - \frac{e^{-\zeta \omega_n t}}{\sqrt{1 - \zeta^2}} \sin \left(\omega_n \sqrt{1 - \zeta^2} t + \alpha \right)$$

Step responses of a second order element over damped $\zeta \geq 1$

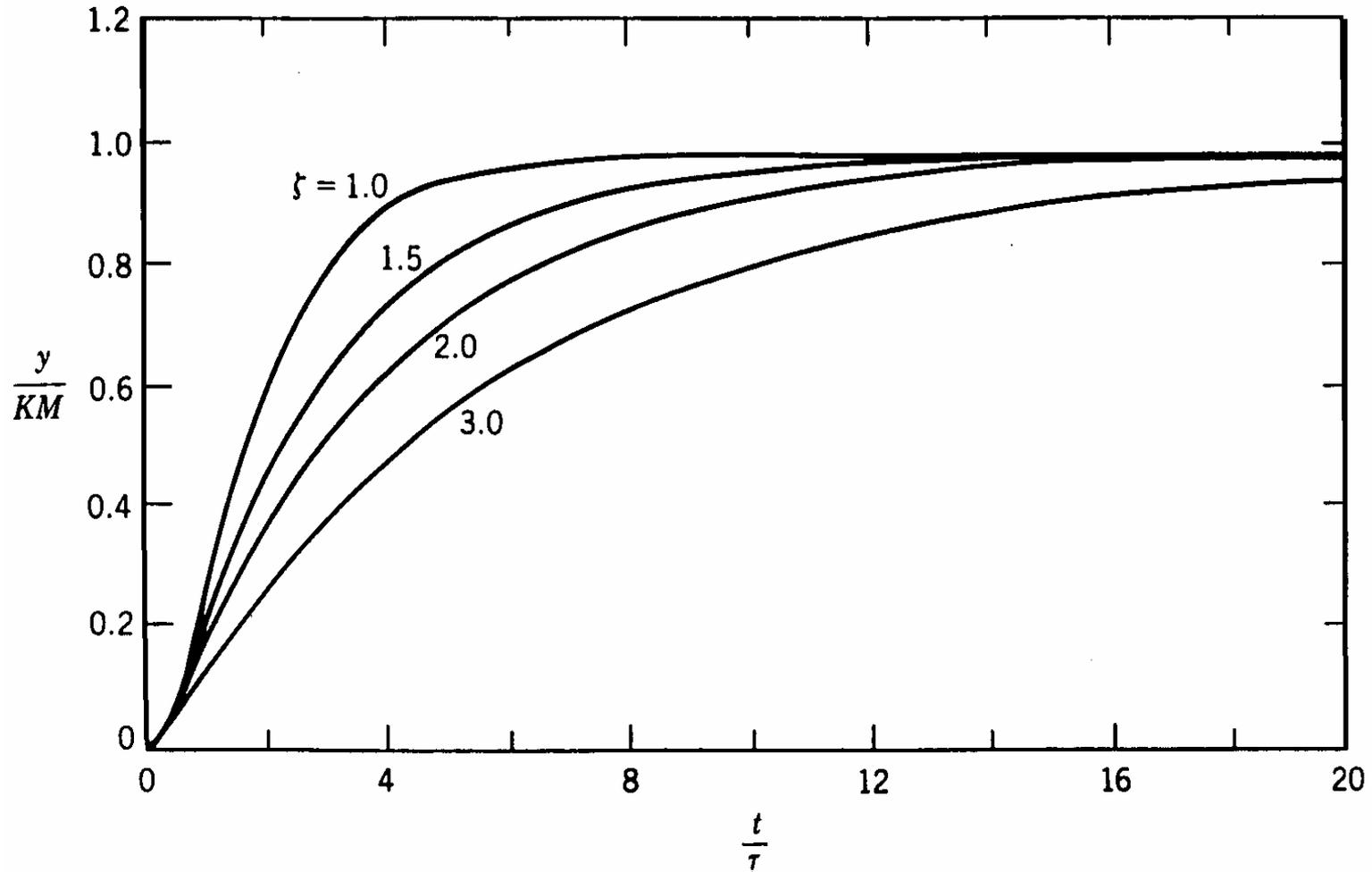

Step responses of a second order element under damped $\zeta < 1$

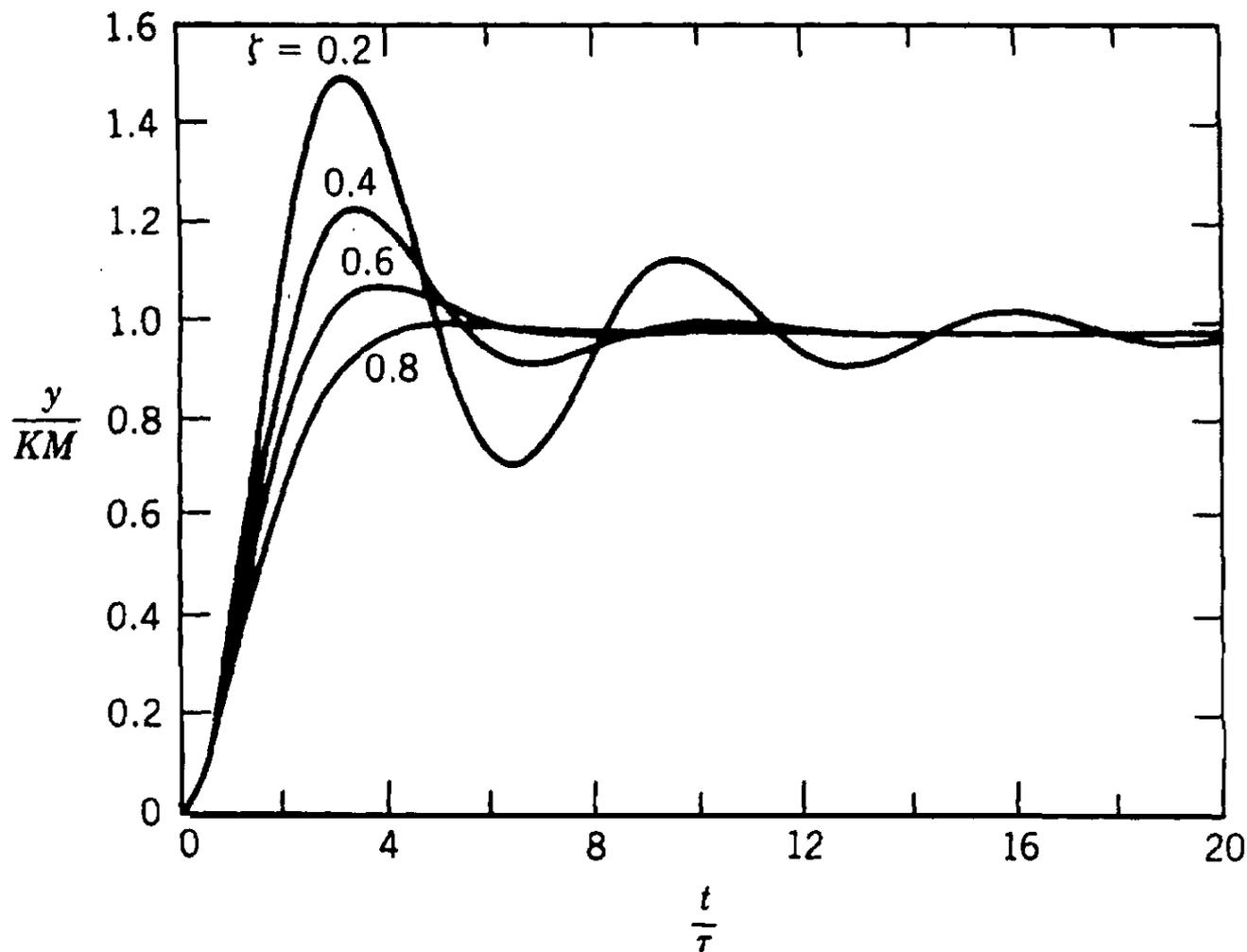

Second order underdamped response specifications

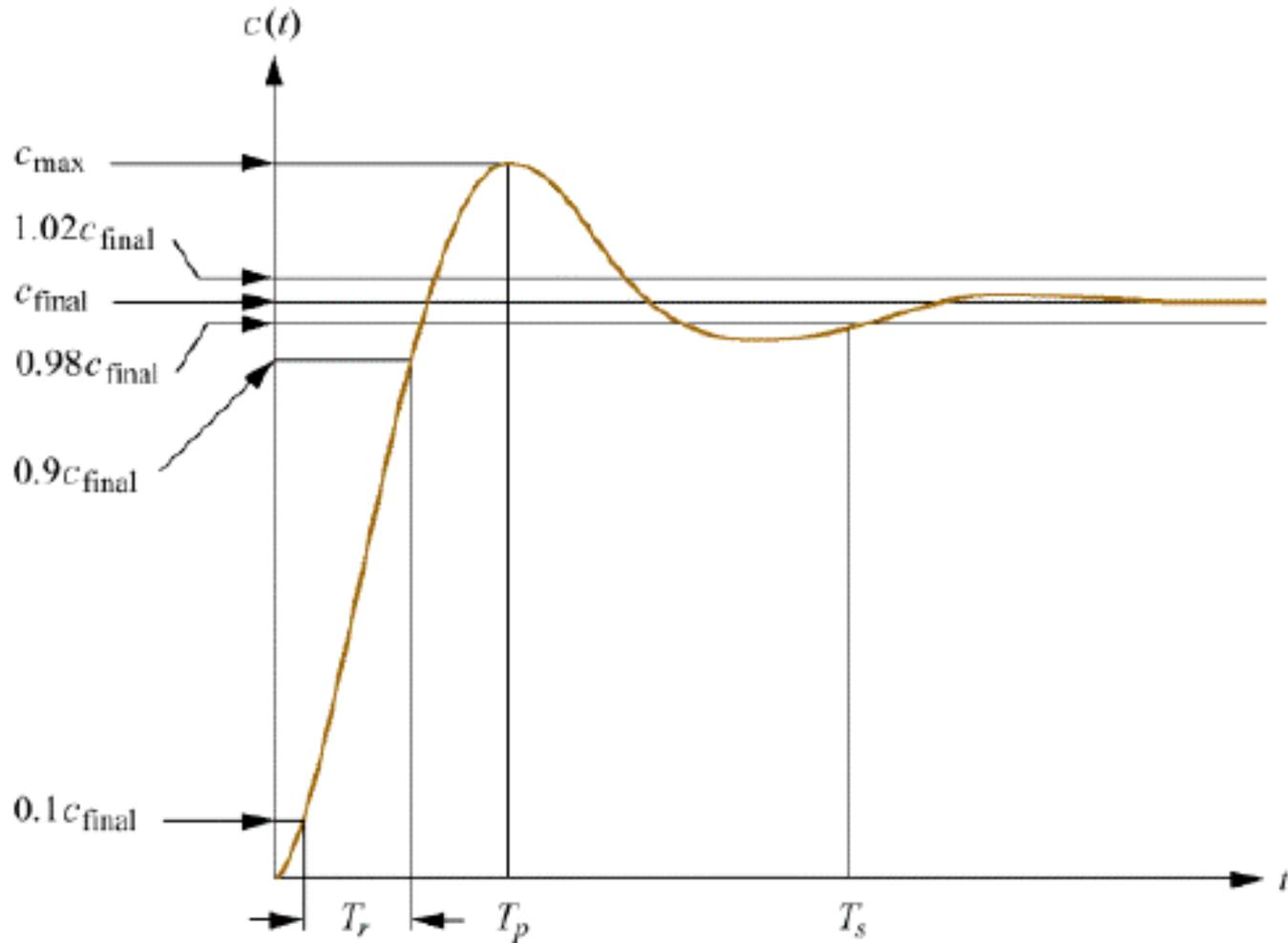

Performance specifications of a second-order system

- **Let**

$$\frac{dc(t)}{dt} = 0$$

- **We have**

$$\omega_n \sqrt{1 - \zeta^2} t = 0, \pi, 2\pi \dots$$

- **therefore**

$$\begin{aligned} c_{\max}(t) &= 1 - \frac{e^{-\zeta\omega_n t}}{\sqrt{1 - \zeta^2}} \sin(\pi + \alpha) \\ &= 1 + \exp\left(\frac{-\zeta\pi}{\sqrt{1 - \zeta^2}}\right) \end{aligned}$$

Performance specifications of a second-order system

- **Peak time T_p** , the time required to reach the first peak

$$T_p = \frac{\pi}{\omega_n \sqrt{1 - \zeta^2}}$$

- **Percent overshoot, %OS** is the amount that the waveform overshoots the final steady-state

$$\%OS = \exp\left(\frac{-\zeta\pi}{\sqrt{1 - \zeta^2}}\right)$$

Performance specifications of a second-order system

- **Settling time T_s** , the time required for damped oscillations to reach and stay within $\pm 2\%$ of the steady-state (final) value

$$T_s = \frac{4}{\zeta\omega_n}$$

- **Rise time T_r** is the time required for the waveform to go from 0.1 to 0.9 of the final value

Location of the Roots in the s-plane and the Transient Response

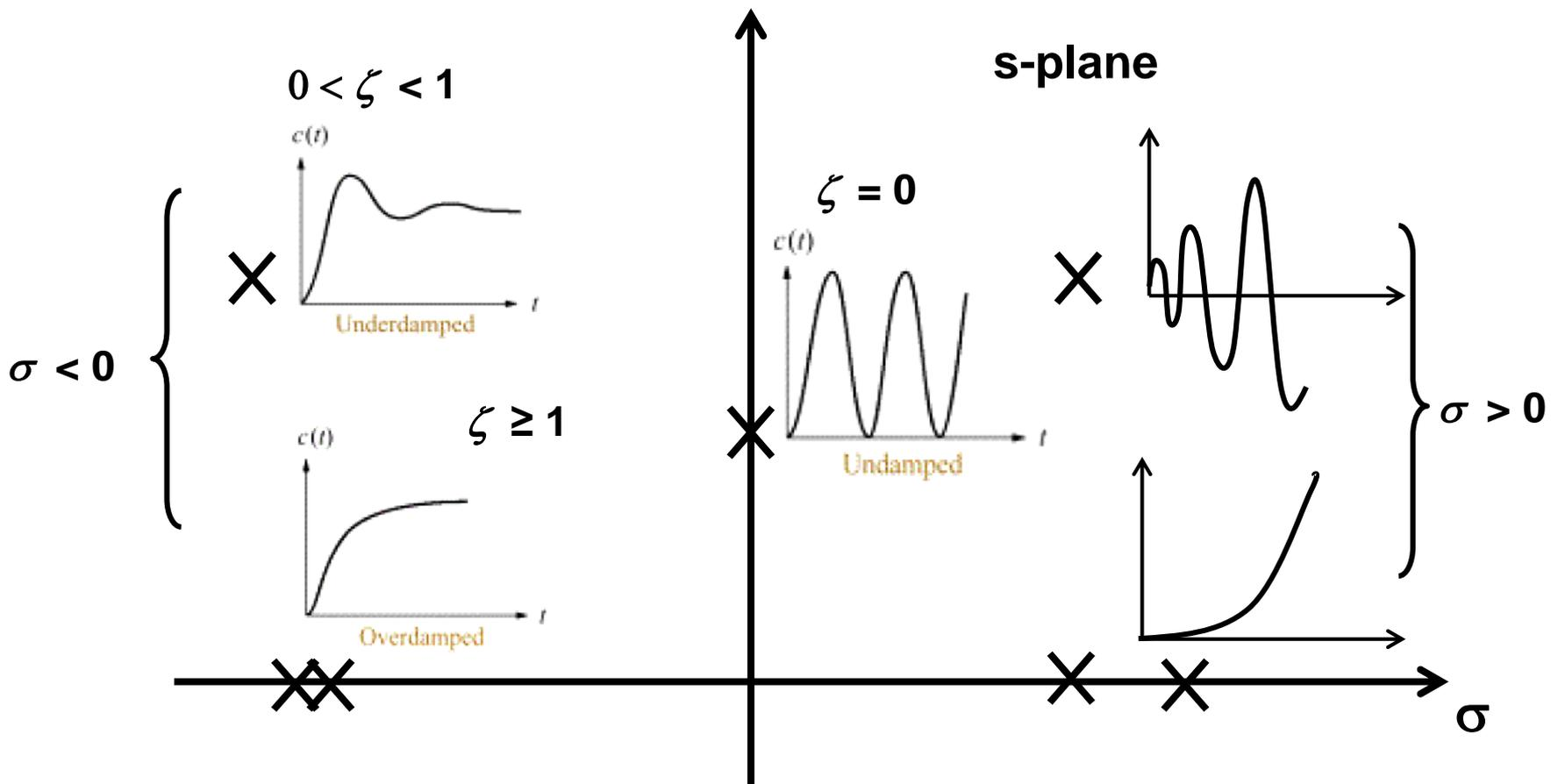

Element Time Response

- **Proportional element**
It is a step with KM as its magnitude
- **Integral element**
It is a ramp at the slop of KM/τ_i
- **Differential element**
It is a impulse
- **Delay element**
It is a step after a time delay of τ

Development of Empirical Dynamic Models from Step Response Data

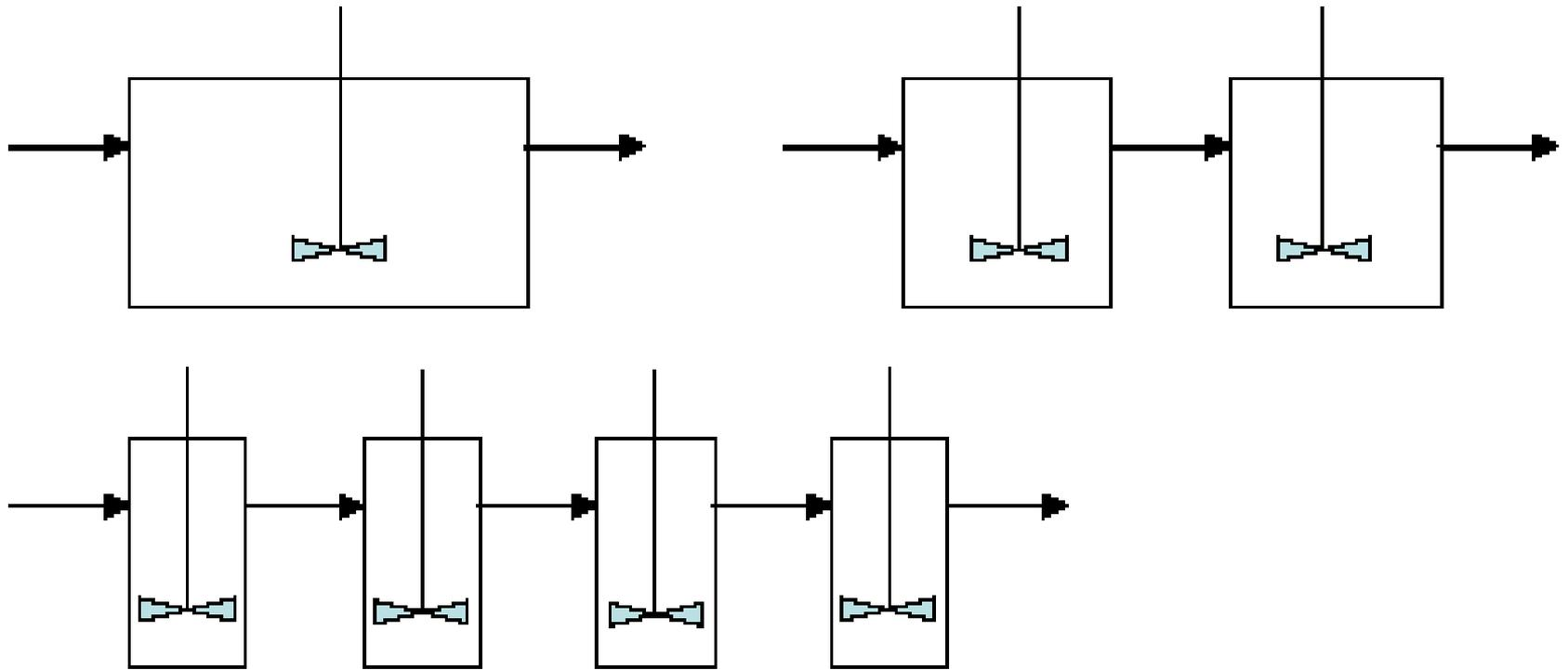

Higher order system and dead time

Higher order system and dead time

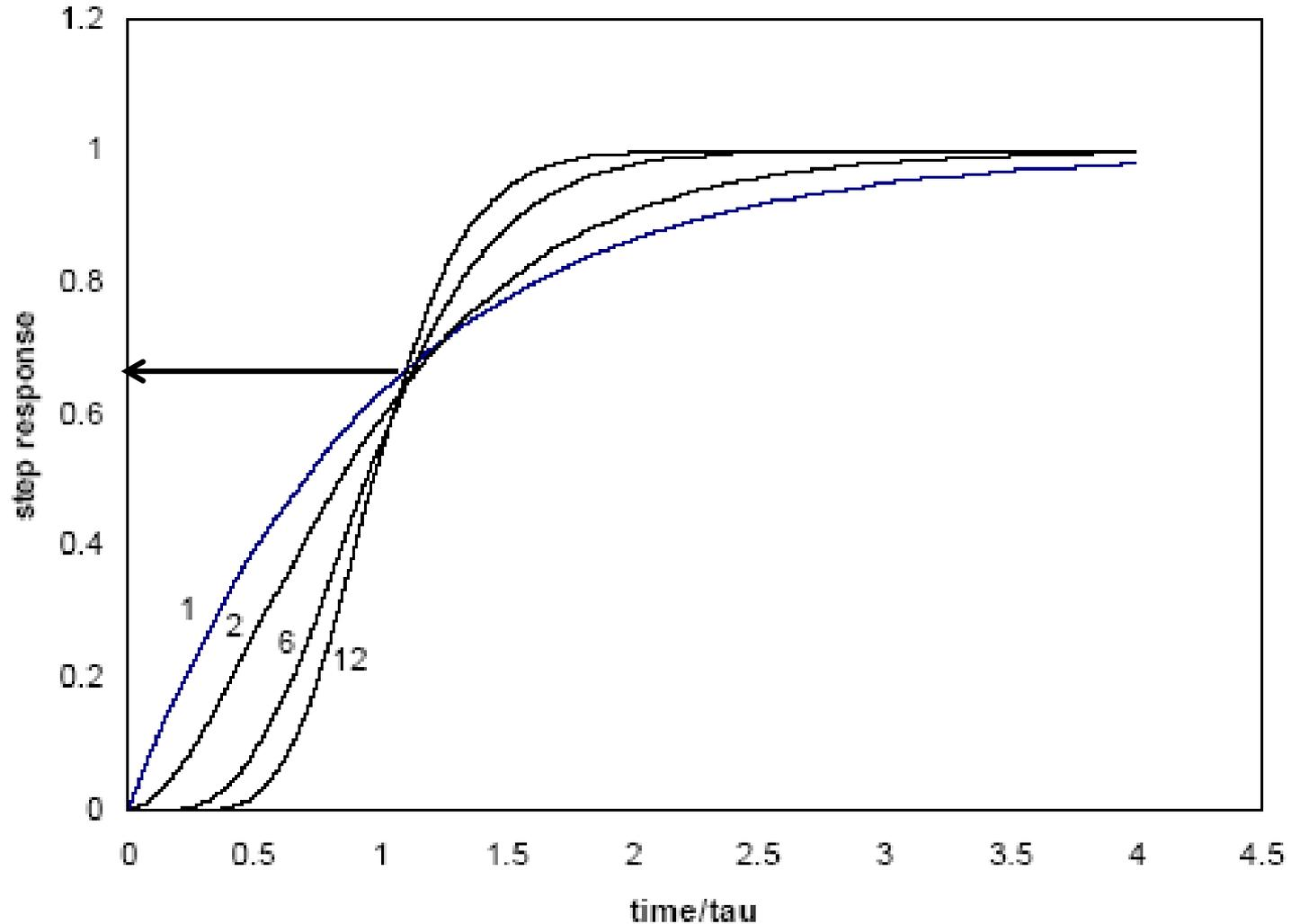

Approximate using first-order-plus-time-delay model

- The response attains 63.2% of its final response at one time constant ($t = \tau + \theta$)
- The line drawn tangent to the response at maximum slope ($t = \theta$) intersects the 100% line at ($t = \tau + \theta$).
- K is found from the steady state response for an input change magnitude M . The step response is essentially complete at $t = 5\tau$.

Approximate using first-order-plus-time-delay model

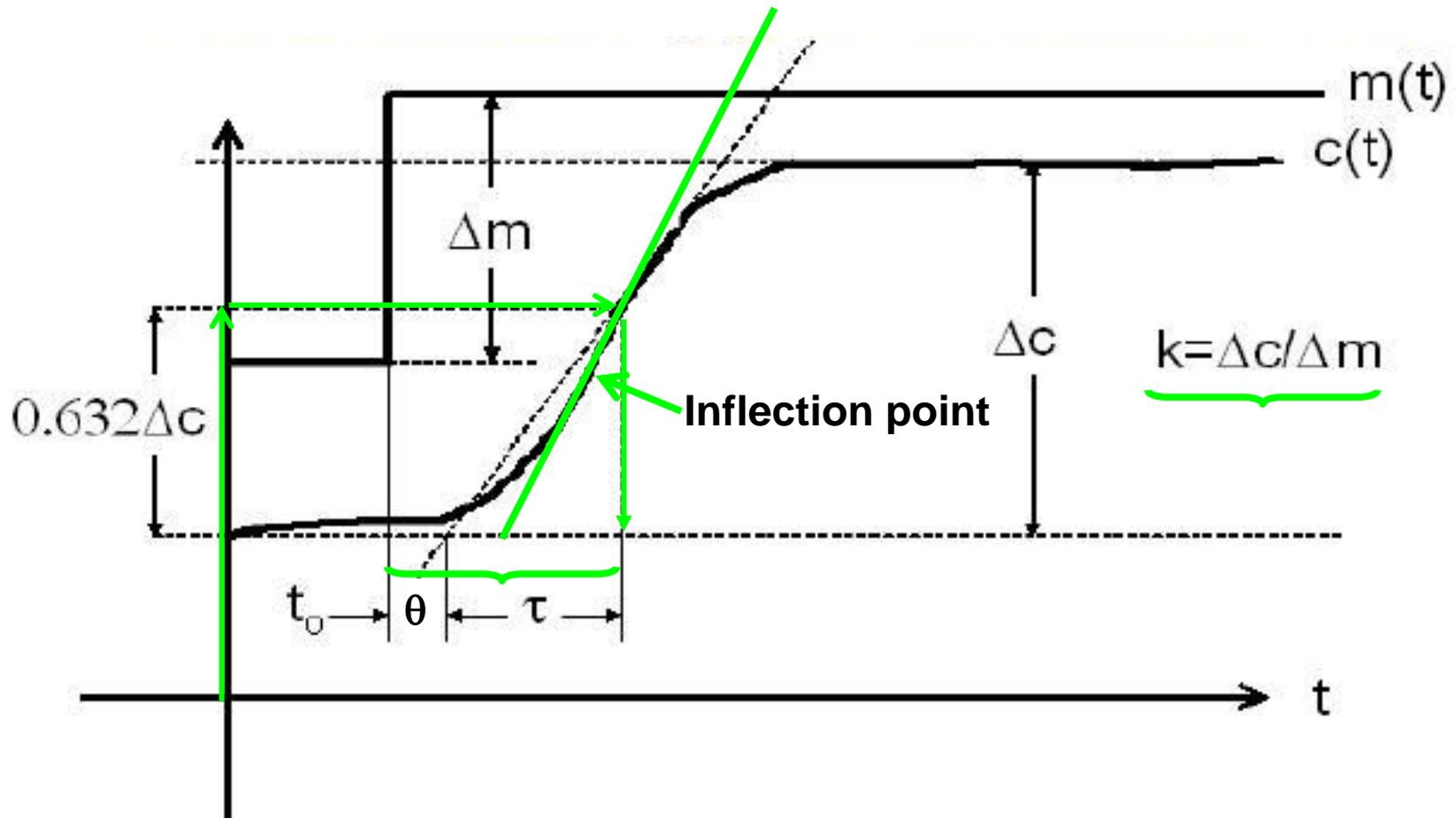

Time Constant

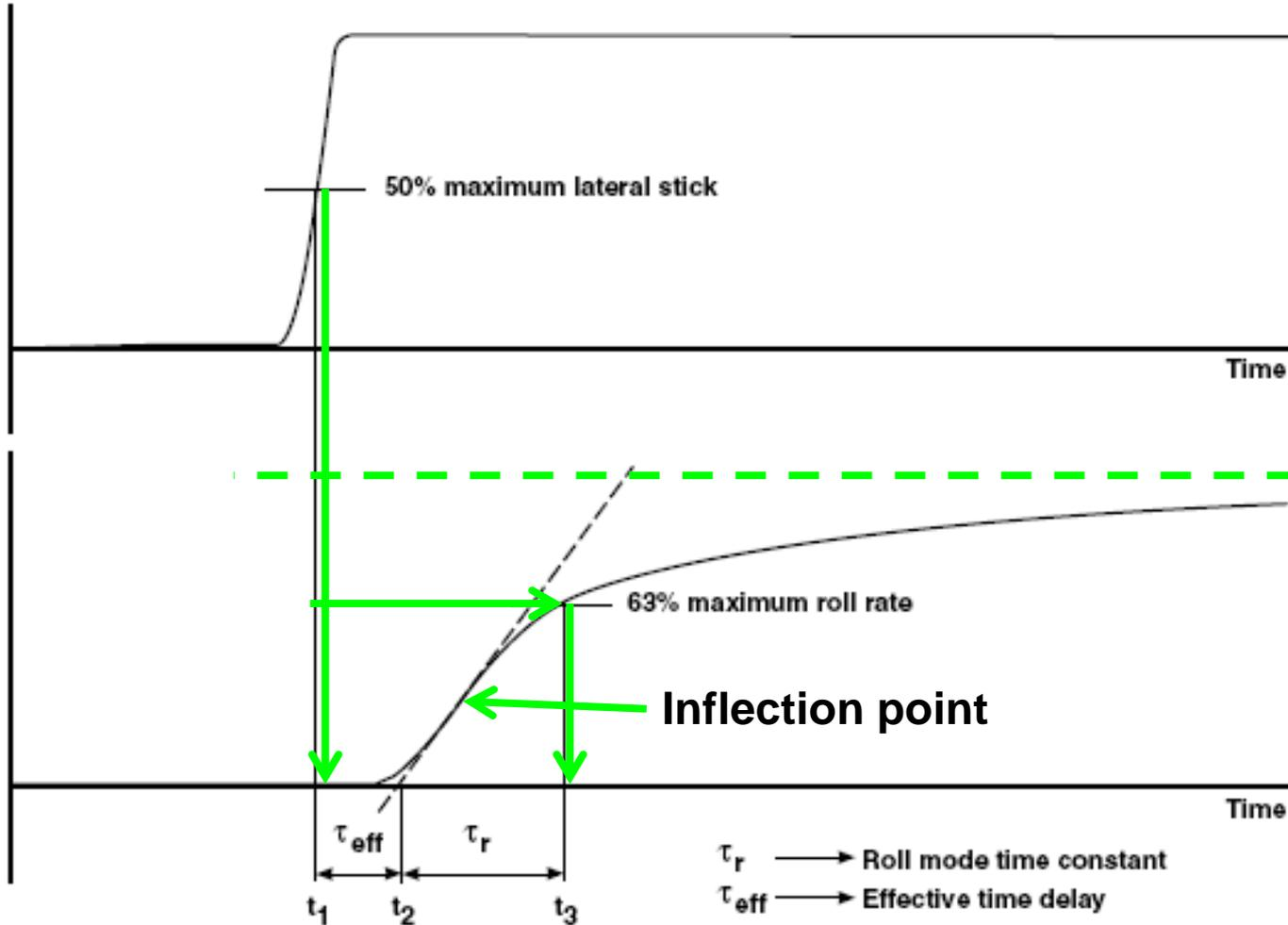

Time Constant

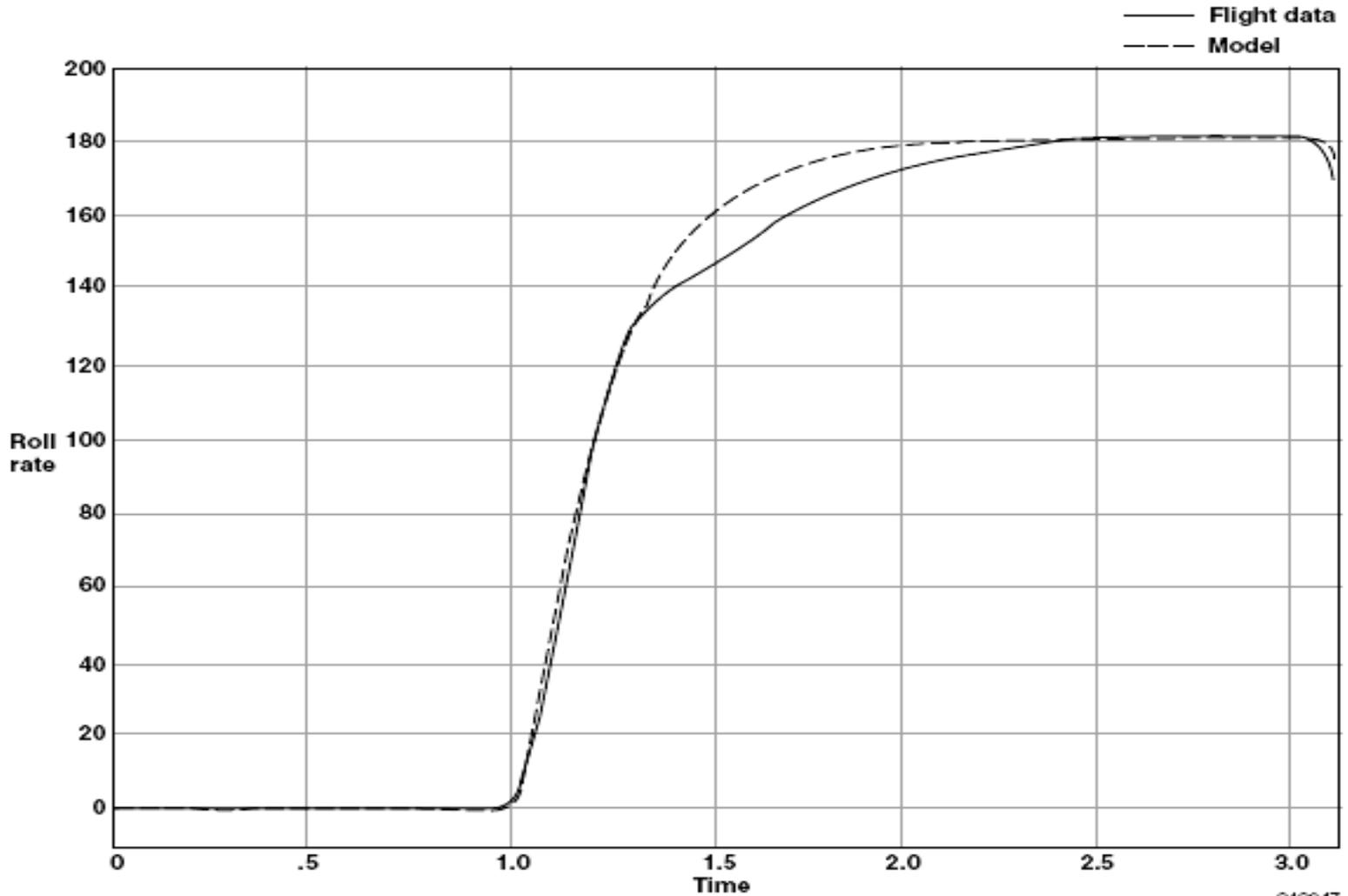

Sundaresan and Krishnaswamy's

Inflection point of the process reaction curve is too arbitrary and difficult to determine when data is noisy

- **Step 1 take 35.3% response time t_1**
- **Step 2 take 85.3% response time t_2**
- **Substitute into the equations**

$$\theta = 1.3t_1 - 0.29t_2$$

$$\tau = 0.67(t_2 - t_1)$$

Time Constant

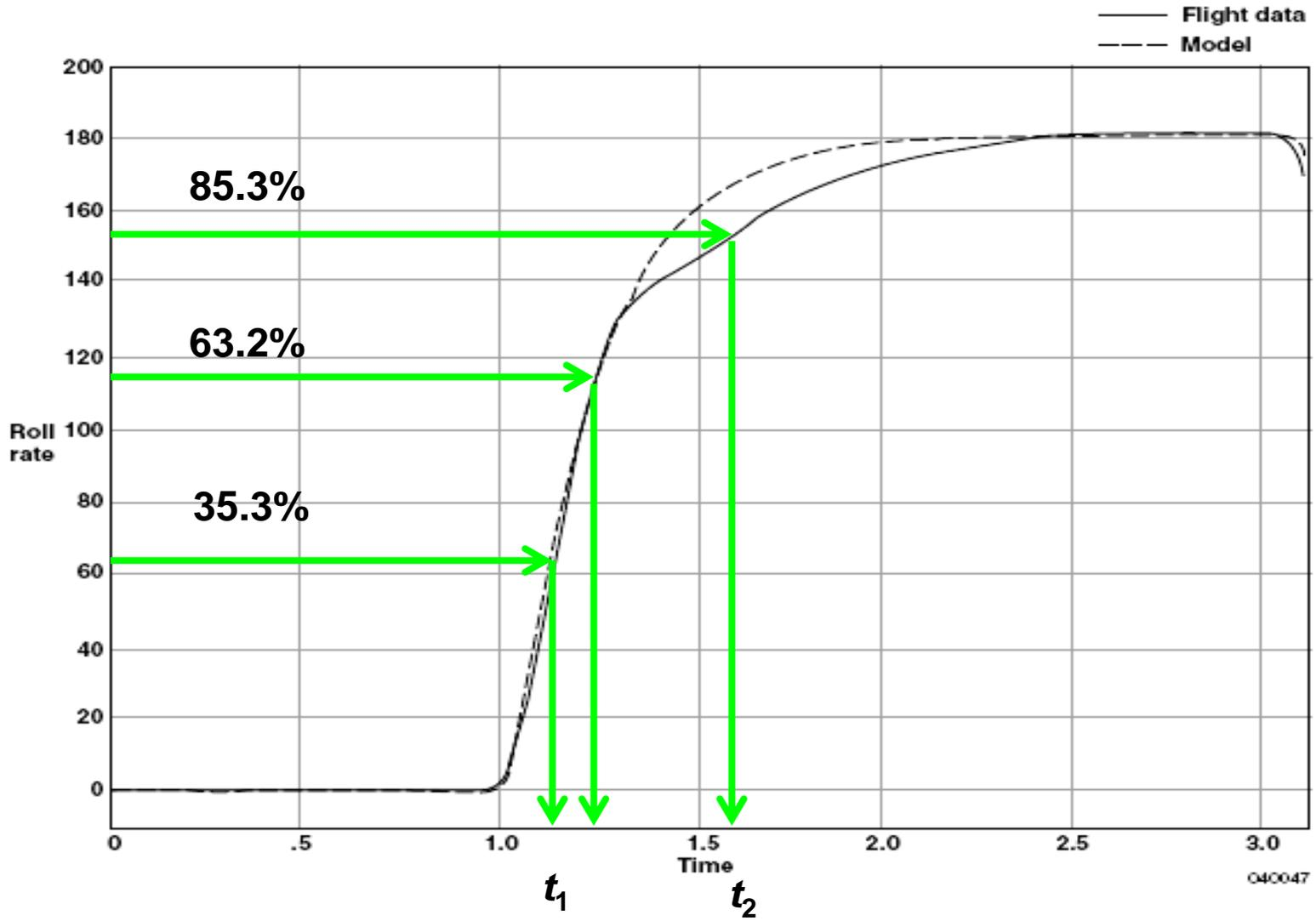

Second-order Model

In general, a better approximation to an experimental step response can be obtained by fitting a second-order model to the data

$$G(s) = \frac{K}{(\tau_1 s + 1)(\tau_2 s + 1)}$$

The larger of the two time constants, τ_1 , is called the dominant time constant

Second-order Model

- **Two limiting cases:**
 - $\tau_1/\tau_2 = 0$, where the system becomes first order, and,
 - $\tau_1/\tau_2 = 1$, the critically damped case ($\zeta=1$)
- **Determine t_{20} and t_{60} from the step response.**
- **Find ζ and t_{60}/τ from Figure 14.**
- **Find t_{60}/τ from Figure 14 and then calculate τ (since t_{60} is known).**

Second-order Model

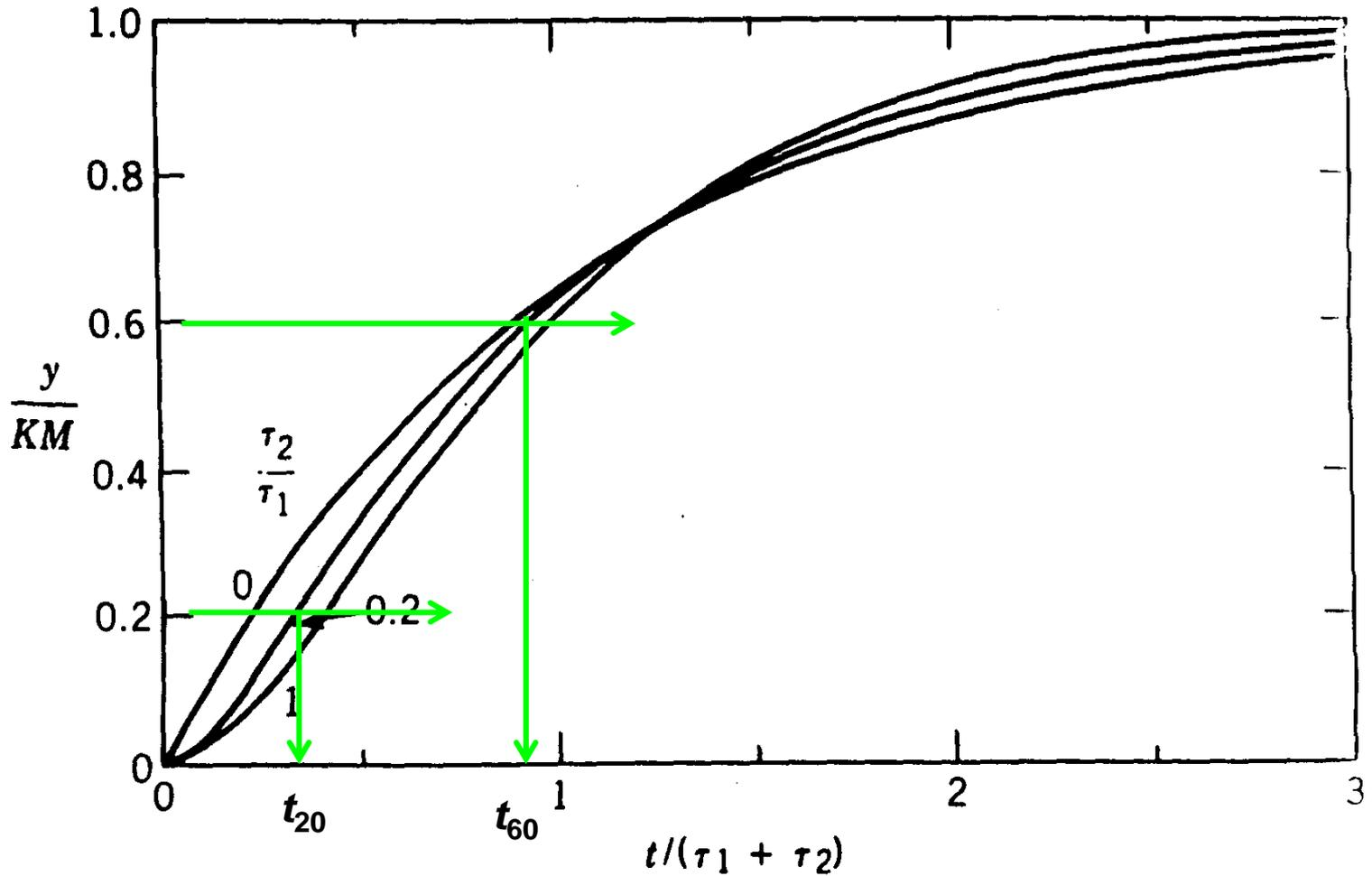

Second-order Model

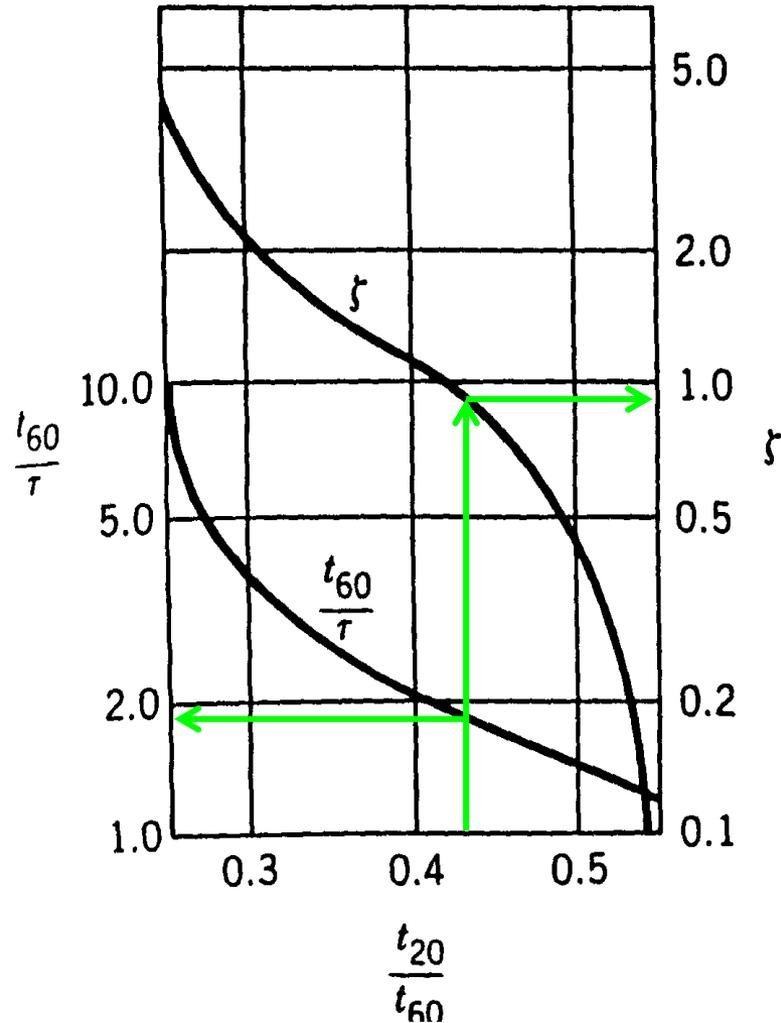

Modeling Second-order Through Least Square Fit

- For unit step input

$$G(s) = \frac{C(s)}{R(s)} = \frac{C(s)}{\frac{1}{s}} = sC(s)$$

- Assume $c(t)$ takes the form,

$$c(t) = c_{ss} + K_1 e^{-at} + K_2 e^{-bt} + \dots$$

where c_{ss} is the final-value of $c(t)$

Table 4.1. Transient Response of Eq. (4.51) to a Unit Step Input to Obtain the Theoretical Value of $c(t)$, the Model Fit Data $\hat{c}(t)$, and the Error between the Theoretical Value of $c(t)$ and the Model Fit Data

Time (sec)	$c(t)$	$\hat{c}(t)$ (Model fit)	error = $c(t)$ - fit of $\hat{c}(t)$
0	0	0	0
0.2000	0.1219	0.3994	-0.2775
0.4000	0.3374	0.6393	-0.3019
0.6000	0.5372	0.7833	-0.2462
0.8000	0.6916	0.8699	-0.1783
1.0000	0.8009	0.9218	-0.1210
1.2000	0.8743	0.9531	-0.0787
1.4000	0.9220	0.9718	-0.0498
1.6000	0.9523	0.9831	-0.0308
1.8000	0.9711	0.9898	-0.0187
2.0000	0.9826	0.9939	-0.0112
2.2000	0.9897	0.9963	-0.0067
2.4000	0.9939	0.9978	-0.0039
2.6000	0.9964	0.9987	-0.0023
2.8000	0.9979	0.9992	-0.0013
3.0000	0.9988	0.9995	-0.0008
3.2000	0.9993	0.9997	-0.0004
3.4000	0.9996	0.9998	-0.0002
3.6000	0.9998	0.9999	-0.0001
3.8000	0.9999	0.9999	-0.0001
4.0000	0.9999	1.0000	0.0000
4.2000	1.0000	1.0000	0.0000
4.4000	1.0000	1.0000	0.0000
4.6000	1.0000	1.0000	0.0000
4.8000	1.0000	1.0000	0.0000
5.0000	1.0000	1.0000	0.0000

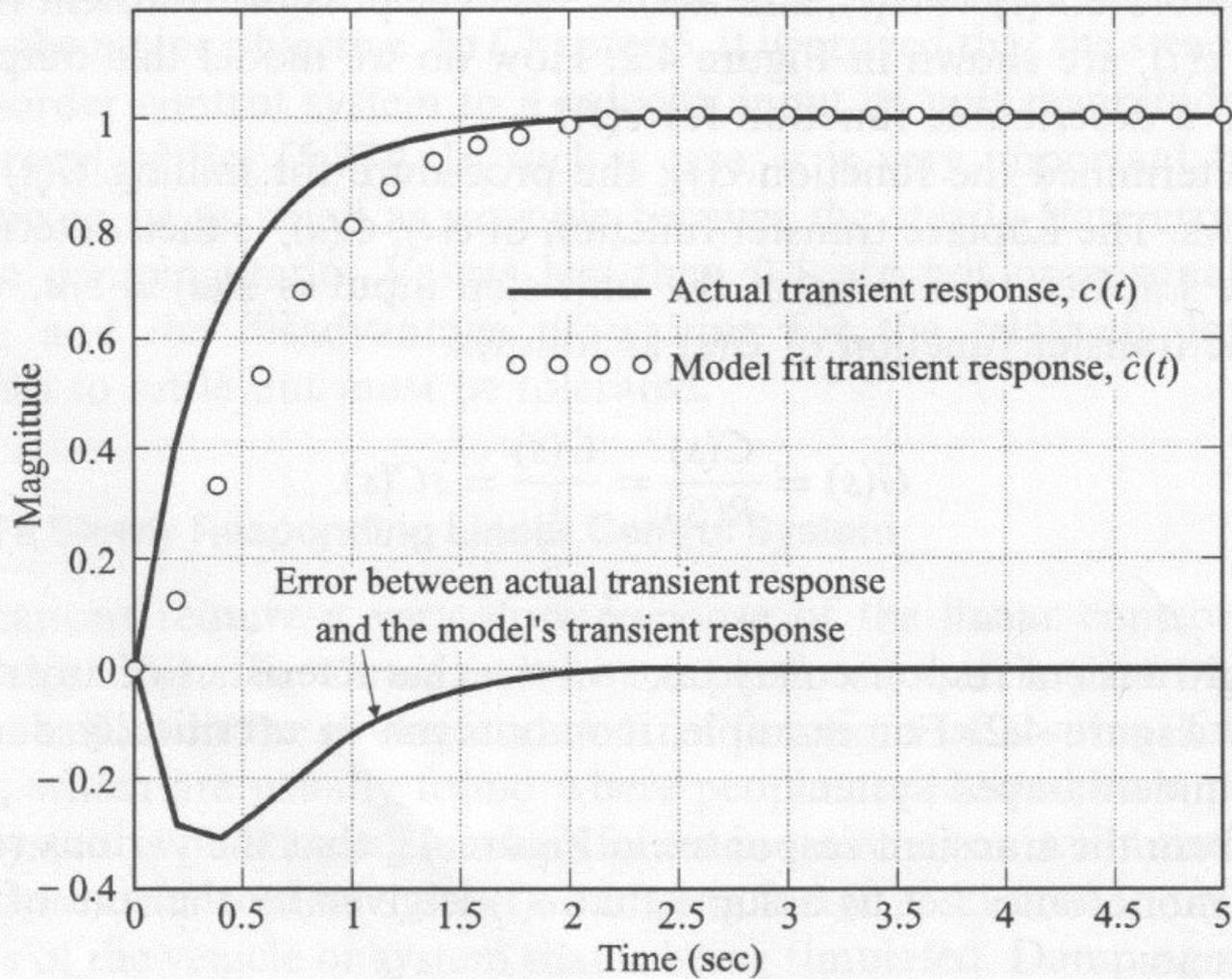

Figure 4.10 Transient response of the control system whose transfer function is given by Eq. (4.51) to a unit step input, and a model fit $\hat{c}(t)$.

Modeling Second-order Through Least Square Fit

- **Step 1: Least square fit first term**

$$c(t) - c_{ss} \approx K_1 e^{-at}$$

$$\begin{aligned} \log(c(t) - c_{ss}) &\approx \log K_1 - at \log e \\ &\approx \log K_1 - 0.4343 at \end{aligned}$$

The intercept is $\log K_1$

The slope is $0.4343a$

Modeling Second-order Through Least Square Fit

- **Step 2: Subtract the line fitted from the experimental data**

$$\log(c(t) - c_{ss}) - \log(K_1 e^{-at}) \approx \log K_2 - 0.4343 bt$$

The intercept is $\log K_2$

The slope is $0.4343b$

Modeling Second-order Through Least Square Fit

- **Step 3: Adjustment to have $c(0) = 0$,**

$$adjustment = -\frac{1 - K_1 - K_1}{2} = ad$$

– **Let**

$$K_1' = K_1 + ad$$

$$K_2' = K_2 + ad$$

– **Now we have,**

$$c(t) = c_{ss} + K_1' e^{-at} + K_2' e^{-bt}$$

Time Responses Using State Variable Method

- For non zero second order system,

$$\frac{C(s)}{R(s)} = \frac{\omega_n^2}{s^2 + 2\zeta\omega_n s + \omega_n^2}$$

- Divide s^2 on both numerator and denominator,

$$\begin{aligned}\frac{C(s)}{R(s)} &= \frac{\omega_n^2 s^{-2}}{(s^2 + 2\zeta\omega_n s + \omega_n^2) s^{-2}} \\ &= \frac{\omega_n^2 s^{-2}}{1 + 2\zeta\omega_n s^{-1} + \omega_n^2 s^{-2}}\end{aligned}$$

Time Responses Using State Variable Method

- Define,

$$E(s) = \frac{R(s)}{1 + 2\zeta\omega_n s^{-1} + \omega_n^2 s^{-2}}$$

- Therefore,

$$C(s) = \omega_n^2 s^{-2} E(s)$$

$$E(s) = R(s) - 2\zeta\omega_n s^{-1} E(s) + \omega_n^2 s^{-2} E(s)$$

Time Responses Using State Variable Method

The state-variable signal-flow graph,

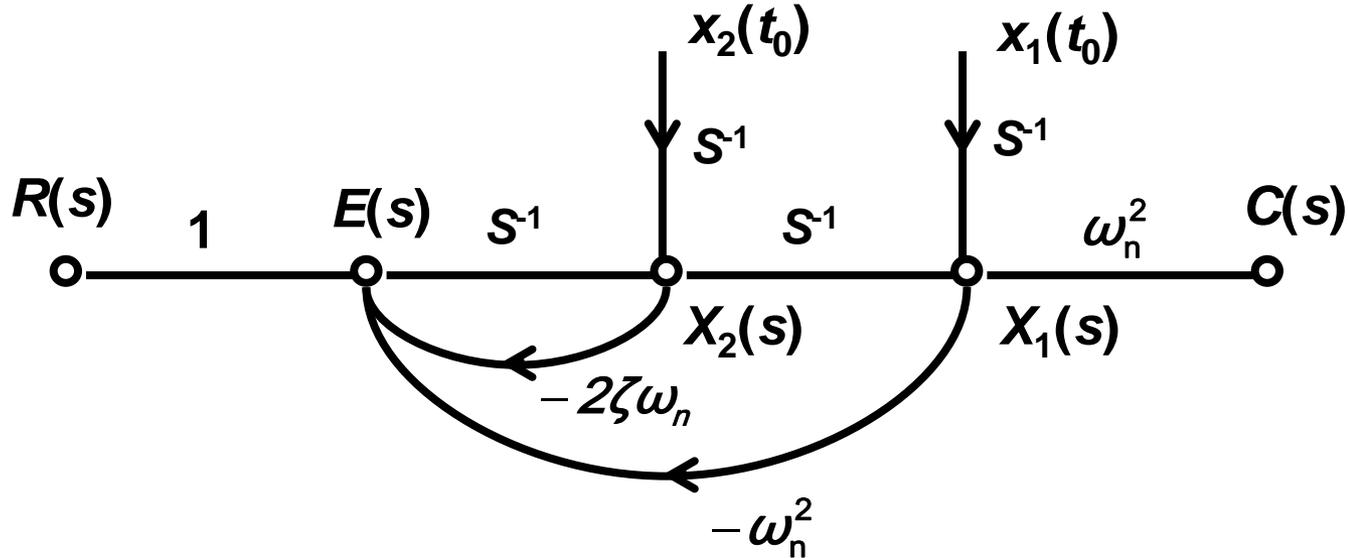

- Example

$$\ddot{c}(t) + 4\dot{c}(t) + 3c(t) = r(t)$$

- Laplace transform,

$$\begin{aligned} \frac{C(s)}{R(s)} &= \frac{1}{s^2 + 4s + 3} \\ &= \frac{s^{-2}}{1 + 4s^{-1} + 3s^{-2}} \end{aligned}$$

- then

$$E(s) = \frac{R(s)}{1 + 4s^{-1} + 3s^{-2}}$$

$$C(s) = s^{-2}E(s)$$

$$E(s) = R(s) - 4s^{-1}E(s) - 3s^{-2}E(s)$$

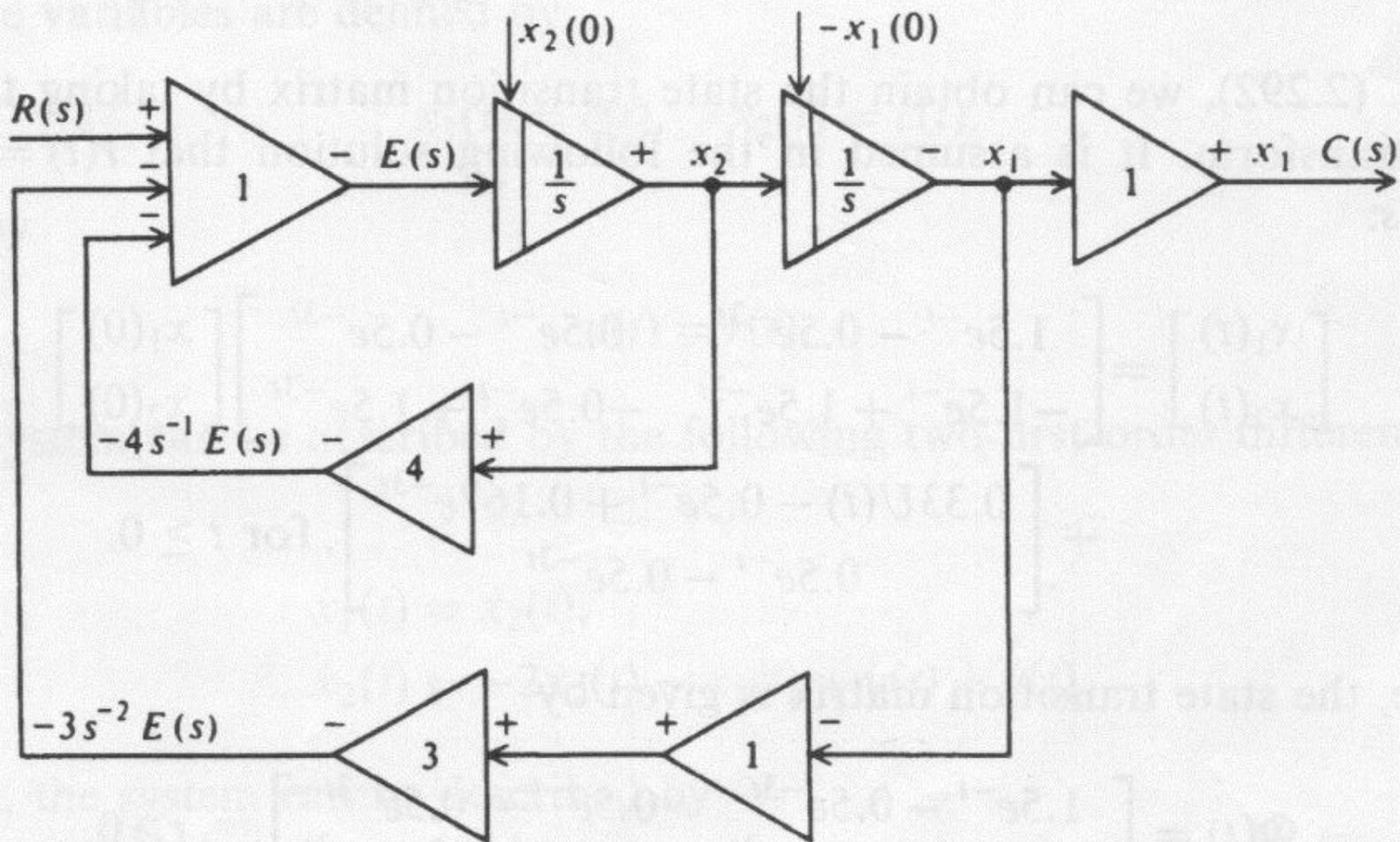
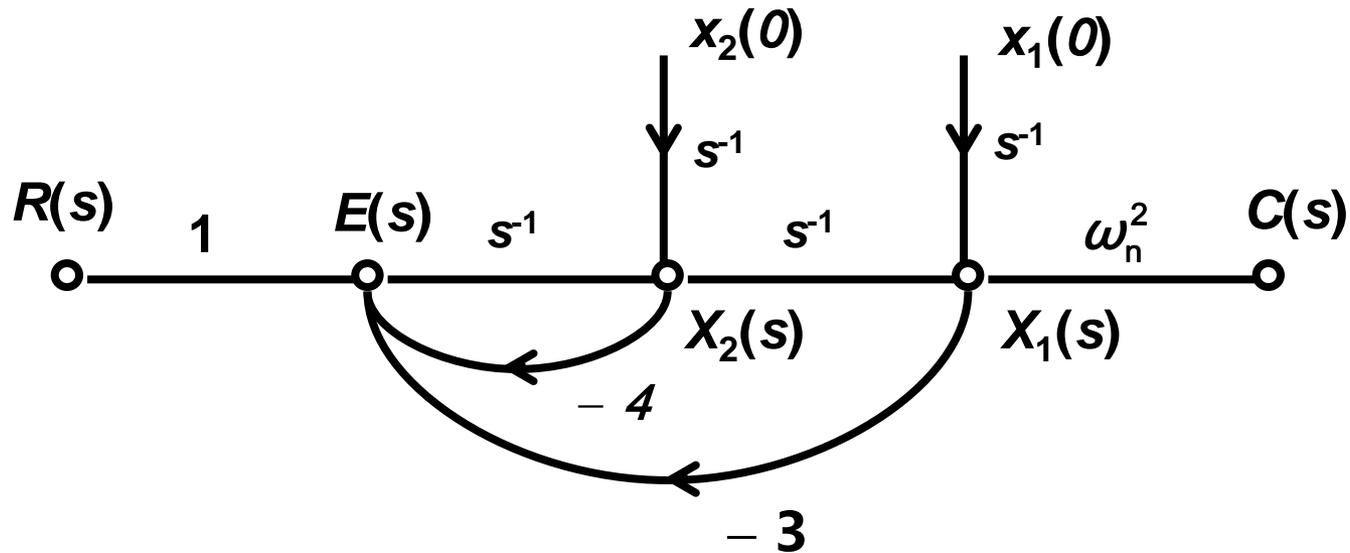

Figure 2.39 State-variable diagram for system where $C(s)/R(s) = 1/(s^2 + 4s + 3)$.



- Quiz 15 min
- Use Mason's theory to find $X_1(s)$ and $X_2(s)$

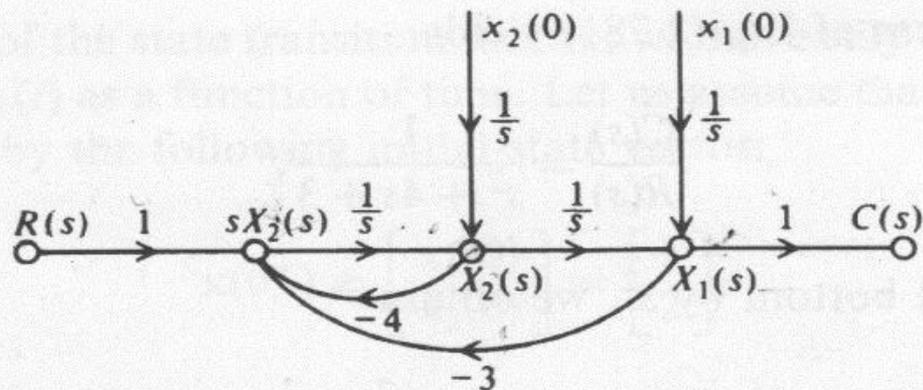

Figure 2.40 State-variable signal-flow graph corresponding to the state-variable diagram of Figure 2.39.

$$X_1(s) = \frac{s^{-1}(1 + 4s^{-1})x_1(0)}{\Delta} + \frac{s^{-2}x_2(0)}{\Delta} + \frac{s^{-2}R(s)}{\Delta}, \quad (2.287)$$

$$X_2(s) = \frac{-3s^{-2}x_1(0)}{\Delta} + \frac{s^{-1}x_2(0)}{\Delta} + \frac{s^{-1}R(s)}{\Delta}, \quad (2.288)$$

where

$$\Delta = 1 - (-4s^{-1} - 3s^{-2}) = 1 + 4s^{-1} + 3s^{-2}. \quad (2.289)$$

Simplifying Eqs. (2.287)–(2.289), we obtain the following pair of equations:

$$X_1(s) = \frac{s+4}{s^2+4s+3}x_1(0) + \frac{1}{s^2+4s+3}x_2(0) + \frac{R(s)}{s^2+4s+3}, \quad (2.290)$$

$$X_2(s) = \frac{-3}{s^2+4s+3}x_1(0) + \frac{s}{s^2+4s+3}x_2(0) + \frac{sR(s)}{s^2+4s+3}. \quad (2.291)$$

These two equations can be put into the following form:

$$\begin{bmatrix} X_1(s) \\ X_2(s) \end{bmatrix} = \frac{1}{(s+1)(s+3)} \begin{bmatrix} s+4 & 1 \\ -3 & s \end{bmatrix} \begin{bmatrix} x_1(0) \\ x_2(0) \end{bmatrix} + \begin{bmatrix} \frac{1}{(s+1)(s+3)} \\ \frac{s}{(s+1)s+3} \end{bmatrix} R(s). \quad (2.292)$$

From Eq. (2.292), we can obtain the state transition matrix by taking the inverse Laplace transform. It is assumed in the following solution that $r(t) = U(t)$ and $R(s) = 1/s$:

$$\begin{bmatrix} x_1(t) \\ x_2(t) \end{bmatrix} = \begin{bmatrix} 1.5e^{-t} - 0.5e^{-3t} & 0.5e^{-t} - 0.5e^{-3t} \\ -1.5e^{-t} + 1.5e^{-3t} & -0.5e^{-t} + 1.5e^{-3t} \end{bmatrix} \begin{bmatrix} x_1(0) \\ x_2(0) \end{bmatrix} + \begin{bmatrix} 0.33U(t) - 0.5e^{-t} + 0.167e^{-3t} \\ 0.5e^{-t} - 0.5e^{-3t} \end{bmatrix}, \text{ for } t \geq 0. \quad (2.293)$$

Therefore, the state transition matrix is given by

$$\Phi(t) = \begin{bmatrix} 1.5e^{-t} - 0.5e^{-3t} & 0.5e^{-t} - 0.5e^{-3t} \\ -1.5e^{-t} + 1.5e^{-3t} & -0.5e^{-t} + 1.5e^{-3t} \end{bmatrix}, \quad t \geq 0. \quad (2.294)$$